



Installation and Maintenance Manual

Electro-Pneumatic Regulator

ITV10*0-DE***-Q,
ITV20*0-DE***-Q,
ITV30*0-DE***-Q



1 Safety Instructions

This manual contains essential information for the protection of users and others from possible injury and/or equipment damage.

- Read this manual before using the product, to ensure correct handling, and read the manuals of related apparatus before use.
- Keep this manual in a safe place for future reference.
- These instructions indicate the level of potential hazard by label of "Caution", "Warning" or "Danger", followed by important safety information which must be carefully followed.
- To ensure safety of personnel and equipment the safety instructions in this manual and the product catalogue must be observed, along with other relevant safety practices.

	Caution	Indicates a hazard with a low level of risk, which if not avoided, could result in minor or moderate injury.
	Warning	Indicates a hazard with a medium level of risk, which if not avoided, could result in death or serious injury.
	Danger	Indicates a hazard with a high level of risk, which if not avoided, will result in death or serious injury.

• Electromagnetic compatibility:

This product is class A equipment intended for use in an industrial environment. There may be potential difficulties in ensuring electromagnetic compatibility in other environments due to conducted as well as radiated disturbances.

Warning

- **The compatibility of pneumatic equipment is the responsibility of the person who designs the pneumatic system or decides its specifications.**

Since the products specified here can be used in various operating conditions, their compatibility with the specific pneumatic system must be based on specifications or after analysis and/or tests to meet specific requirements.

- **Only trained personnel should operate pneumatically operated machinery and equipment.**

Compressed air can be dangerous if an operator is unfamiliar with it. Assembly, handling or repair of pneumatic systems should be performed by trained and experienced personnel.

- **Do not service machinery/equipment or attempt to remove components until safety is confirmed.**

- Inspection and maintenance of machinery/equipment should only be performed after confirmation of safe locked-out control positions.
- When equipment is to be removed, confirm the safety process as mentioned above. Switch off air and electrical supplies and exhaust all residual compressed air in the system.

- Before machinery/equipment is re-started, ensure all safety measures to prevent sudden movement of cylinders etc. (Supply air into the system gradually to create back pressure, i.e. incorporate a soft-start valve).

- **Do not use this product outside of the specifications. Contact SMC if it is to be used in any of the following conditions:**

- Conditions and environments beyond the given specifications, or if the product is to be used outdoors.
- Installations in conjunction with atomic energy, railway, air navigation, vehicles, medical equipment, food and beverage, recreation equipment, emergency stop circuits, press applications, or safety equipment.
- An application, which has the possibility of having negative effects on people, property, or animals, requiring special safety analysis.

Caution

- Ensure that the air supply system is filtered to 5 microns.

2 Specifications

Model	ITV*010	ITV*030	ITV*050	ITV2090
Min. supply pressure	(Set pressure) + 0.1 MPa			(Set pressure) -13.3 kPa
Max. supply pressure	0.2 MPa	1.0 MPa	1.0 MPa	-101 kPa
Set pressure range	0.005 ~ 0.1 MPa	0.005 ~ 0.5 MPa	0.005 ~ 0.9 MPa	-1.3 ~ -80 kPa
Supply voltage	24 VDC±10%			
Current consumption	Max. 140 mA			
Input/output data	12 bit/12 bit (data 4095 corresponds to 100%F.S.)			
Linearity	Max. ±1%F.S.			
Hysteresis	Max. 0.5%F.S.			
Repeatability	Max. ±0.5%F.S.			
Sensitivity	Max. 0.2%F.S.			
Temperature characteristics	Max. ±0.12%F.S./°C			
Operating temperature	0~50°C (without condensation)			
Protection structure	IP65			
Model	ITV10*0	ITV20*0	ITV30*0	
Size (mm)	50×50×109	50×50×131	66×66×152	
Weight (No option)	320 g	420 g	720 g	

Table 1.

3 Operation Principle

When the input signal increases the supply solenoid valve ① turns on and the exhaust solenoid valve ② turns off. Supply pressure is passed to the pilot valve ③ through the supply solenoid valve. The pilot valve will open the main valve allowing partial supply pressure to pass to the out port. The pressure sensor ④ will provide output pressure feedback to the control circuit ⑤. The control circuit will balance the input signal and output pressure to ensure that the output pressure remains proportional to the input signal.

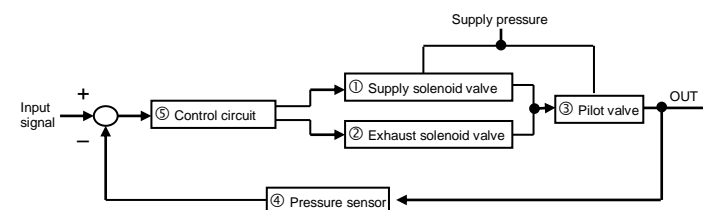

Fig. 1 - Control diagram

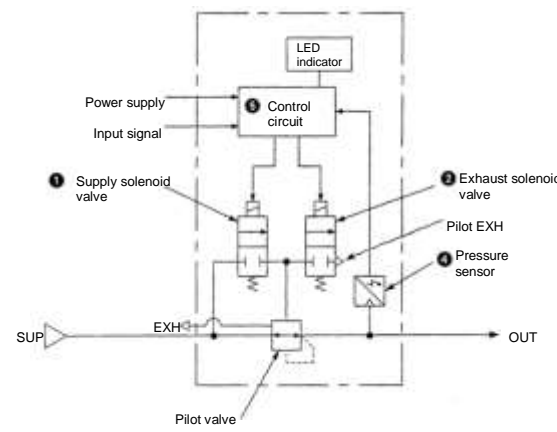

Fig. 2 - Schematic diagram

4 Wiring

Caution

Connect the cable to the connector on the main unit as shown in the following diagram. Take precautions, as incorrect wiring will damage the unit. Use a DC power supply capable of supplying the necessary power requirements with minimal ripple. When 3 m straight cable connection is specified, this refers to the power supply cable, the communications cable should be ordered separately.

Item	Pin assignment	Wire colour (Note)
Connector for power supply	1. +24 V	Brown
	2. N.C.	-
	3. GND	Blue
	4. N.C.	-
Connector for communication	1. Drain	-
	2. V+	Red
	3. V-	Black
	4. CAN_H	White
	5. CAN_L	Blue

Note: Wire colour when the optional cable is used.

Caution

If the communication cable (5 pins) is connected to the power supply instead of the power cable (4 pins) the internal substrate can break. Take care, when connecting the cables.

5 LED Display and Communication Protocol

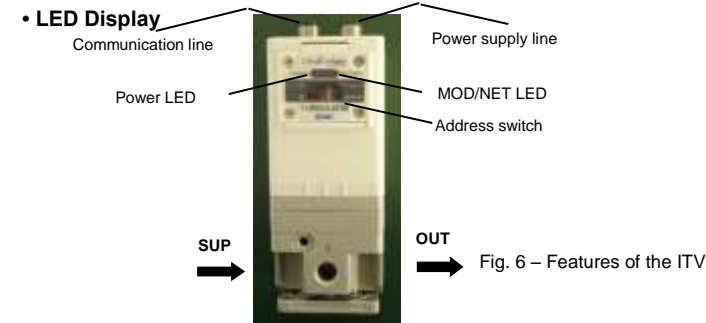

Fig. 6 - Features of the ITV.

Item	LED ON	LED FLASHING	LED OFF
Power	Power ON (Green)	-	Power OFF
MOD/NET	ON line (Green)	No communication (Green)	OFF line
	Fatal error (Red)	Negligible error (Red) (I/O connection time out)	

• Communication Protocol

Item	Specifications	Remarks
Field bus	DeviceNet™	Volume1: (Edition 3.8) Volume3: (Edition 1.5)
EDS file	ITV-A.EDS	
Slave type	Group 2 only	
Device type	00h (Generic device)	
MAC ID	0 to 63	Due to the dip switch or the master
Baud rate (Note)	125k/ 250k/ 500k/ bps	Due to the dip switch or the master
Consumed connection size	2 byte (pooled I/O connection)	Target value of pressure
Produced connection size	2 byte (pooled I/O connection)	Pressure monitor value
Support message	Polled I/O Explicit	

Note: Baud rate relates to the communication distance.

6 DIP Switch Setting

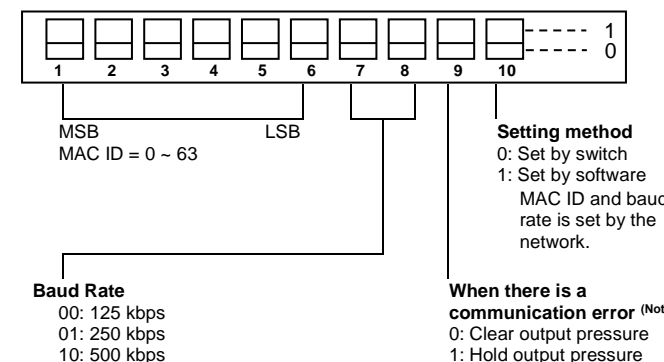

6 DIP Switch Setting (continued)

Note:

- This switch is used to set whether the output pressure is held or cleared if there is a communication error, e.g. if the D-Net communication line is disconnected.
- If the ITV power supply is cut off during communication, the output pressure is held. The status from when the power is turned back on until communication begins, depends on the setting of dip switch No.9
- Setting the address switch requires the removal of 4 screws in the front panel of the unit (Fig 6). Take care as the panel hinges to a maximum of 90 degrees.
- After setting an address, always close and fix the panel securely. Tighten the screws to torque of 0.6 – 0.8 N•m.

7 Communication Data Allocation

I/O data (Poll command sending and receiving data)

Item	Output (Poll request)	Input (Poll response)
Data size	2 Byte (16 bit)	2 Byte (16 bit)
Communication data	b ₁₅ , b ₁₄ , ..., b ₁ , b ₀	b ₁₅ , b ₁₄ , ..., b ₁ , b ₀

The I/O data occupies two bytes respectively.

The pressure is set (output) or is monitored (input) by the data (b₁₅...b₀) Subordinate position 12 bit (b₁₁...b₀) corresponds to 100 %F.S. pressure. The pressure setting is assumed that data 17FEh at 150 %F.S. is a limit value. Accuracy is guaranteed to 100 %F.S.

Pressure can be set by sending the input data, in which F.S. consists of 12 bits, to the E/P regulator through the master PLC (target value to word area).

Setting data	0000h	0FFFh	[(a/F.S.) x 4095] _{HEX}
Output pressure	0 % x F.S. (=0)	100 % x F.S.	a

8 Installation & Maintenance

Caution

- This product is pre-set at the factory and must not be dismantled by the user. Contact your local SMC office for advice.
- Ensure, when installing this product, that it is kept clear of power lines to avoid noise interference.
- Ensure that load surge protection is fitted when inductive loads are present (i.e. solenoid, relay etc.).
- Ensure precautions are in place if the product is used in a 'free flow output' condition. Air will continue to flow continuously.
- Do not use a lubricator on the input side of this product. If lubrication is necessary, place the lubricator on the 'output' side.
- Ensure all air is exhausted from the product before maintenance.
- Length of connector cable shall be 10 m maximum.

9 Contacts

AUSTRIA	(43) 2262 62280	NETHERLANDS	(31) 20 531 8888
BELGIUM	(32) 3 355 1464	NORWAY	(47) 67 12 90 20
CZECH REP.	(420) 541 424 611	POLAND	(48) 22 211 9600
DENMARK	(45) 7025 2900	PORTUGAL	(351) 21 471 1880
FINLAND	(358) 207 513513	SLOVAKIA	(421) 2 444 56725
FRANCE	(33) 1 6476 1000	SLOVENIA	(386) 73 885 412
GERMANY	(49) 6103 4020	SPAIN	(34) 945 184 100
GREECE	(30) 210 271 7265	SWEDEN	(46) 8 603 1200
HUNGARY	(36) 23 511 390	SWITZERLAND	(41) 52 396 3131
IRELAND	(353) 1 403 9000	UNITED KINGDOM	(44) 1908 563888
ITALY	(39) 02 92711		

SMC Corporation

URL : [http:// www.smcworld.com](http://www.smcworld.com) (Global) <http:// www.smceu.com> (Europe)

Specifications are subject to change without prior notice from the manufacturer.

© 2011 SMC Corporation All Rights Reserved.